

CSIR-JRF-NET

Life Sciences

MOCK TEST

MOCK TEST

Pattern of questions : MCQs

Total marks : 200

Duration of test : 3 Hours

This Test Booklet will contain 145 (**Part-A (20), Part-B (50), Part-C (75)**) multiple choice questions.

Part A will be common to all subjects. This part will be a test containing a maximum of 20 questions of General Science and Research Aptitude test. The candidates will be required to answer any 15 questions of two marks each. The total marks allocated to this section will be 30 out of 200.

Part B will contain subject-related conventional MCQs. The total marks allocated to this section will be 70 out of 200. The maximum number of questions to be attempted will be 35 out of 50.

Part C will contain 75 questions that are designed to test a candidate's knowledge of scientific concepts and/or application of the scientific concepts. The questions will be of analytical nature where a candidate is expected to apply the scientific knowledge to arrive at the solution to the given scientific problem. A candidate will be required to answer any 25 questions. Each question will be of four marks. The total marks allocated to this section shall be 100 out of 200.

In case any candidate answers more than 15, 35 and 25 questions in Part A, B and C respectively, only first 15, 35 and 25 questions in Parts A, B and C respectively will be evaluated. There will be negative marking @25% for each wrong answer.



Address

**Pathfinder Academy,
G-92, 115, Pratap Complex,
Pratap Market, Munirka,
New Delhi-110067**

Phone

**011-46038540
011-65661498
09818063394**

**www.pathfinderacademy.in
www.thepathfinder.in**

PATHFINDER ACADEMY

PART-A

- When a solid melts, which of the following is *true*?
 - $\Delta H > 0, \Delta S > 0$
 - $\Delta H < 0, \Delta S < 0$
 - $\Delta H > 0, \Delta S < 0$
 - $\Delta H < 0, \Delta S > 0$
- At equilibrium, _____.
 - all chemical reactions have ceased
 - the rate constants of the forward and reverse reactions are equal
 - the rates of the forward and reverse reactions are equal
 - the value of the equilibrium constant is 1
- Use the graph below to answer the question that follows.

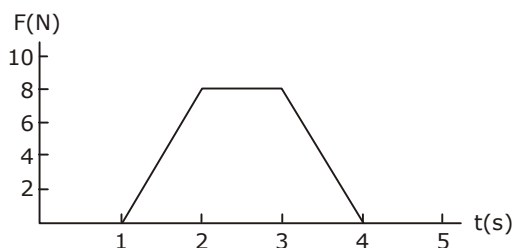

- The graph above shows the magnitude of a force as a function of time. At $t = 0$, a 10 kg object is moving at 4.0 m/s. The force shown on the graph is applied to the object in the direction of motion. What is the momentum of the object at $t = 5$?
- 16 kgm/s
 - 24 kgm/s
 - 40 kgm/s
 - 56 kgm/s
- Which of the following is *not* a geometric sequence?
 - $\{1/10, 3/20, 9/40, \dots\}$
 - $\{24, 18, 13.5, \dots\}$
 - $\{0.8, 0.08, 0.008, \dots\}$
 - $\{1/2, 1/3, 1/4, \dots\}$
 - Fat-soluble vitamins are
 - B, C and D
 - B, D and E
 - A, D and E
 - A, B and C

6. Which of the following cities and times would most favor the following reaction sequences?
- $$\text{N}_{2(g)} + \text{O}_{2(g)} \rightarrow 2\text{NO}_{(g)}$$
- $$2\text{NO}_{(g)} + \text{O}_{2(g)} \rightarrow 2\text{NO}_{2(g)}$$
- $$\text{NO}_{2(g)} + h\nu \rightarrow \text{NO}_{(g)} + \text{O}_{(g)}$$
- $$\text{O}_{(g)} + \text{O}_{2(g)} \rightarrow \text{O}_{3(g)}$$
- New York in January
 - Mexico City in August
 - Honolulu anytime
 - all would favor the reaction equally
7. Students measure the circumference and diameter of a number of circular objects and graph the circumference on the y -axis and the diameter on the x -axis. The students then draw a line that seems to best fit the data points. How can the students use their graphs to estimate the value of π ?
- find the length of the line
 - find the slope of the line
 - find the y -intercept of the line
 - find the midpoint of the line
8. An electronic lock on a door has 6 buttons numbered 1–6. The door will open only when a certain 4-digit sequence is entered. The digits in the sequence must all be different. What is the probability that a random sequence of 4 digits will open the door?
- $6 \times 5 \times 4 \times 3$
 - $\frac{1}{6}C_4$
 - $\frac{1}{6}P_4$
 - $4/6!$
9. After counting 0, 1, 10, 11, the next binary number is
- 12
 - 100
 - 101
 - 110
10. Which one of the following is *not* a plant hormone?
- abscisic acid
 - auxin
 - ethylene
 - cytokine
11. What type of function would best model the data in the table below?
- | | | | | | |
|---|-----|-----|----|----|----|
| x | -15 | -12 | -9 | -6 | -3 |
| Y | 64 | 32 | 16 | 8 | 4 |
- linear
 - quadratic
 - exponential
 - logarithmic

12. Select the *correct* statement about viruses
- viruses consume host cells by ingestion
 - viruses depend on the host cells for respiration
 - viruses reproduce outside the host cells and spread infection to other host cells
 - viruses do not have any metabolic process occurring within themselves
13. Which of the following statements describes the role of a buffer?
- it increases the rate of a reaction
 - it keeps the pH of a solution within a small range
 - it changes the oxidation states of elements in a compound
 - it shifts the reaction equilibrium to favor more product formation
14. Which of the following is lower for a 1.0-molar aqueous solution of any solute than it is for pure water?
- pH
 - vapor pressure
 - freezing point
 - electrical conductivity
15. Net primary productivity is
- the difference between gross primary productivity and community respiration
 - the rate of production of biomass by heterotrophs
 - the mass of living plants per unit area in a community
 - the total rate of fixation of energy by photosynthesis
16. Below is a velocity vs. time graph showing the movement of a train over time. Use this graph to answer the following question.

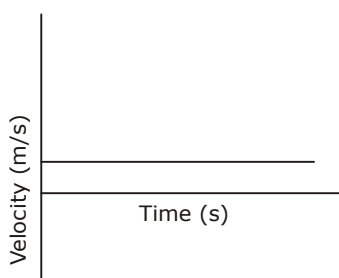

- Which of the following statements is the best description of the train's motion? The train is
- not moving in any direction
 - continuously accelerating
 - moving with a constant velocity
 - accelerating slowly
17. Which type of organic molecule is an enzyme?
- carbohydrate
 - lipid
 - DNA
 - protein

18. How do fungi differ from plants?
- fungi lack a cell wall
 - fungi lack chlorophyll
 - fungi lack a nucleus
 - fungi need nutrients in order to grow
19. Suppose X and Y are independent random variables. The variance of X is equal to 16; and the variance of Y is equal to 9. Let $Z = X - Y$.
What is the standard deviation of Z?
- 2.65
 - 5.00
 - 7.00
 - 25.0
20. Substances X and Y that were in a solution were separated in the laboratory using the technique of fractional crystallization. This fractional crystallization is possible because substances X and Y have different
- boiling points
 - melting points
 - densities
 - solubilities

PART-B

21. Organized clathrin structures are typically associated with the
- nuclear envelope and endoplasmic reticulum
 - lysosomes
 - trans*-Golgi network and plasma membrane
 - extracellular matrix
22. The molecular formula for glucose is $C_6H_{12}O_6$. What would be the molecular formula for a polymer made by linking ten glucose molecules together by dehydration reactions?
- $C_{60}H_{120}O_{60}$
 - $C_6H_{12}O_6$
 - $C_{60}H_{102}O_{51}$
 - $C_{60}H_{100}O_{50}$
23. A man with hemophilia (a recessive, sex linked condition) has a daughter of normal phenotype. She marries a man who is normal for the trait.
- P. the probability that a daughter of this mating will be a hemophiliac is 0.
Q. the probability a son will be a hemophiliac is 1/2
R. if the couple has four sons, the probability that all four will be born with hemophilia is 1/16
- P and Q
 - Q and R
 - P and R
 - P, Q and R

24. Choose *correct* statement with regard to insulin
- P. it is a 51 amino acid peptide
 - Q. it is formed by removal of C-chain from proinsulin
 - R. it is produced by the alpha cells of the pancreas
 - S. its receptor is GPCR
- a. Q, S
 - b. P, Q
 - c. P, R
 - d. Q, R
25. Identify the *correct* statement regarding gastrulation
- P. formation of archenteron surrounded by the endoderm
 - Q. little growth so that overall size of the embryo does not increase significantly
 - R. greater activity of the nucleus and the formation of new proteins
 - S. complex but orderly and irreversible morphogenetic movements
- a. P, Q
 - b. only S
 - c. Q, R
 - d. P, Q, R, S
26. Identify the *correct* statements. In *Arabidopsis*, vernalization is associated with
- P. chromatin modification at the FLC (Flowering Locus C) locus
 - Q. degradation of the FLC protein
 - R. inactivating the FLC protein by post-translational modification
 - S. down-regulation of FLC transcript
- a. Q, S
 - b. P, S
 - c. P, R
 - d. Q, R
27. In the kidney the *correct* sequence of formation of urine involves the following processes
- a. glomerular filtration, reabsorption, tubular secretion
 - b. reabsorption, filtration, secretion
 - c. filtration, secretion, reabsorption
 - d. reabsorption, secretion, filtration
28. In a cross involving polygenic inheritance where three gene pairs control plant height, the shortest and tallest plants are 6 cm and 24 cm, respectively. What height should all F_1 s display if homozygous 12-cm and 24-cm plants are crossed, assuming their environments are the same?
- a. 15 cm
 - b. 21 cm
 - c. 18 cm
 - d. 12 cm

29. Which of the following is not involved in protein transport into mitochondria?
- a. a positively charged sequence of about 20 to 35 amino acids located at the N-terminus
 - b. the TOM complex
 - c. the proton gradient across the inner mitochondrial membrane
 - d. vesicular transport
30. Which is *not* correct about ribulose-1,5-bisphosphate carboxylase?
- a. makes up about 50 percent of the chloroplast protein
 - b. is located in the same compartment as the oxygen-generating complex
 - c. is encoded by a combination of nuclear and chloroplast DNA
 - d. is located in the compartment where starch is stored
31. Which of the following statements about the structure and properties of cytochrome *c* are *incorrect*?
- P. it is an integral membrane protein
 - Q. it contains very little alpha-helix or beta-pleated sheet secondary structure
 - R. it lacks a heme
 - S. it has retained a highly conserved conformation throughout evolution
 - T. it is soluble in water
- a. P, Q, R
 - b. P, Q, R, S
 - c. P, R, S, T
 - d. Q, R, S, T
32. At least 10 percent of human DNA exists as repeated multiples of relatively short sequences of nucleotides. Which of the following statements about this repetitive DNA is *correct*?
- a. much of the repetitive DNA is transcribed into messenger RNA
 - b. repetitive DNA is largely responsible for the production of enzymes and other protein molecules
 - c. most repeated sequences are associated with detectable phenotypes
 - d. highly repeated sequences rapidly reassociate in DNA hybridization studies
33. Which of the following statements about yeast are *correct*?
- P. yeast are fungi
 - Q. yeast can form pseudohyphae
 - R. yeast reproduce asexually by budding
 - S. yeast are facultative anaerobes
 - T. all yeast are pathogenic
 - U. all yeast are dimorphic
- a. P, Q, R and S
 - b. R, S, T and U
 - c. P, R, S and U
 - d. Q, R, S and T

34. Gal⁻ mutants of *E.coli* cannot use galactose as a carbon source. When these mutants are infected with phage lambda that has been grown on wild-type *E.coli*, however, the progeny bacteria can use galactose. This genome alteration is an example of bacterial
- transformation
 - transduction
 - conjugation
 - transposition
35. Evidence indicating that chloroplasts were originally free-living prokaryotes that subsequently evolved a symbiotic relationship with a eukaryotic host includes all of the following *except*
- similarities in structure between chloroplasts and prokaryotes
 - presence of circular DNA in chloroplasts and prokaryotes
 - susceptibility of chloroplasts to prokaryotic protein synthesis inhibitors
 - ability of chloroplasts to synthesize all their own proteins
36. Which of the following statement is *true* for *Fasciola hepatica* (liver fluke)?
- it is triploblastic, platyhelminth and lives in bile duct of the host
 - it is diploblastic, trematode and lives in liver of the host
 - it is triploblastic, nematode and lives in pancreas of the host
 - it is diploblastic, platyhelminth and lives in bile duct of the host
37. Which of the following are *true* concerning estrogen?
- P. they promote development of secondary sex character
Q. they lower blood cholesterol
R. in moderate level they inhibit release of GnRH and the secretion of LH and FSH
S. they increase protein catabolism
- P and S
 - Q, R and S
 - P, Q and R
 - P, Q, R and S
38. The conformation of a nucleotide in DNA is affected by rotation about how many bonds?
- 4
 - 6
 - 7
 - 3
39. Deletion of the leader sequence of *trp* operon of *E. coli* would result in
- decreased transcription of *trp* operon
 - increased transcription of *trp* operon
 - no effect on transcription
 - decreased transcription of *trp* operon in the presence of tryptophan

40. Which of the following is/are *true*?
- P. Plant cell wall is composed of the same monomer as the yeast cell wall
 - Q. Plant cells are dividing faster than the yeast cells
 - R. During division of plant cells, Golgi complex plays vital role in the telophase
 - S. Cellulose is a branched polymer
- a. P only
 - b. R only
 - c. Q and R
 - d. R and S
41. What would stop DNA replication in bacteria?
- P. addition of a DNA polymerase inhibitor
 - Q. addition of dideoxynucleotides (ddNTP)
 - R. addition of lamin inhibitor
 - S. addition of actin inhibitor
- a. P and Q
 - b. Q and R
 - c. R and S
 - d. P and S
42. Which of the following statements about sterols is *true*?
- a. sterols are found in the membranes of all living cells
 - b. the principal sterol of animal cells is ergosterol
 - c. all sterols share a fused-ring structure with four rings
 - d. sterols are very soluble in water, but less so in organic solvents such as chloroform
43. In haplontic life cycle
- a. only gametophytic generation is present
 - b. only sporophytic generation is present
 - c. predominant gametophytic generation is present
 - d. predominant sporophytic generation is present
44. Orthologs
- P. are always located on the same chromosome
 - Q. have similar amino acid sequence
 - R. have identical promoters
 - S. have similar functions
- a. P only
 - b. R only
 - c. Q and R
 - d. Q and S

45. The major immunoglobulin family to which a particular immunoglobulin belongs can be determined by sequential analysis of the 100 amino acids beginning from the
- amino-terminal of the light chain
 - carboxy-terminal of the light chain
 - amino-terminal of the heavy chain
 - carboxy-terminal of the heavy chain
46. A bacterial culture was diluted 1000 fold and 0.1 ml of this diluted sample was spread per plate on nutrient agar. In a triplicate run, the number of colonies formed is 121, 93 and 86, the number of colony forming units/ml in the original bacterial culture is
- 10^6
 - 10^5
 - 10^3
 - 10^2
47. The mechanisms regulating the decision between lysis and lysogeny for bacteriophage lambda have been described as 'genetic switch'. Which of the following statements are true of the systems?
- the cI and cro genes are transcribed in opposite directions
 - the mRNAs encoding cI and cro protein are synthesized using the same strand of DNA as template
 - synthesis of cI is not stimulated by its binding to O_R2
 - of the three O_R sites in the lambda genome, cI has greatest affinity for O_{R1}
- P and Q
 - P and S
 - Q and R
 - R and S
48. A mixture of four proteins of pIs 11, 7, 5 and 3 are loaded on DEAE anion-exchange column equilibrated with low ionic strength buffer of pH 8. Which of the four proteins would be expected to be retained on the column?
- protein with pI 11 but not the others
 - proteins with pIs 11 and 7 but not 5 and 3
 - proteins with pIs 7, 5 and 3
 - protein with pI 7 but not the others
49. Plants bend toward a light source as a result of
- the increased amount of food synthesized by their leaves
 - an unequal auxin distribution in their stems
 - the necessity of light for transpiration
 - an inability to synthesize chemical regulators

50. Expression in poor amount and inactive form of a eukaryotic protein from eukaryotic gene in *Escherichia coli* using its expression vector is due to
- P. the absence of capping mechanism of mRNA
 - Q. codon bias
 - R. absence of polyadenylation
 - S. absence of proper glycosylation
- a. P, Q
 - b. Q, R
 - c. Q, S
 - d. P, S
51. Which amongst the following represent pancreatic enzymes?
- a. maltase aminopeptidase, nucleosidase
 - b. trypsin, chymotrypsin, nucleotidase, carboxypeptidase
 - c. trypsin, chymotrypsin, lingual lipase enterokinase
 - d. trypsin, chymotrypsin, carboxypeptidase, aminopeptidase
52. Which of the following statements is the most appropriate example of character displacement?
- a. two related species depending on the same prey species avoid competition by feeding at different times of the day
 - b. the body sizes of two related species are very similar when they are allopatric, but in geographical areas of sympatry, one species is significantly smaller than the other
 - c. the food niche of a species is generally wider in the absence of competing species than in their presence
 - d. closely related species can coexist if their densities are regulated by a predator
53. Okazaki fragments were prepared from an *E.coli* strain harboring pBR322 plasmid. These fragments were then hybridized to single stranded DNA molecules prepared by carefully separating the two strands of the *E.coli* chromosome and the plasmid. The Okazaki fragments would anneal to
- a. both the strands of the chromosome and the plasmid
 - b. both the strands of the chromosome but only one strand of the plasmid
 - c. one strand of the chromosome but both the strands of the plasmid
 - d. one strand each of the chromosome and the plasmid
54. The decreasing order of the melting points of the following fatty acids is
- P. Stearic acid, 18 : 0
 - Q. *Cis*-oleic acid, 18 : 1
 - R. *Trans*-oleic acid, 18 : 1
 - S. Linolenic acid, 18 : 3
- a. P > Q > R > S
 - b. P > R > Q > S
 - c. S > R > Q > P
 - d. S > Q > R > P

55. Which of the following covalent bond types are found in the structure of ATP?
- N-glycosidic, thioester, phosphodiester
 - phosphoanhydride, phosphomonoester, N-glycosidic
 - ester, ether, phosphoanhydride
 - ether, thioester, phosphomonoester
56. The phenomenon of *independent assortment* refers to:
- expression at the same stage of development
 - unlinked transmission of genes in crosses resulting from being located on different chromosomes, or far apart on the same chromosome
 - segregation of genes present on homologous chromosomes independently
 - independent location of genes from each other in an interphase cell
57. Double fertilization
- results in individuals with an extra copy of one of the sex chromosomes
 - is the mechanism by which monozygotic but not dizygotic twins are produced
 - is the mechanism by which two sperm nuclei fertilize an oocyte and two endosperm nuclei, respectively
 - is the mechanism by which dizygotic but not monozygotic twins are produced
58. Cheetahs in the Serengeti population in Africa show very low levels of heterozygosity. Which of the following processes is *least* likely to cause such a pattern?
- a founder effect
 - a bottleneck event
 - frequent migration events between connected populations
 - frequent breeding events between close relatives
59. Which of the following is responsible for formation of polytene chromosomes?
- nondisjunction of chromatids during meiosis
 - recombination of sister chromatids
 - repeated replication without separation of sister chromatids
 - recombination between adjacent chromatids
60. A nucleic acid has following base composition:
- A: 30 percent
G: 40 percent
- What can be inferred from this data?
- the nucleic acid is a RNA
 - the nucleic acid is a DNA
 - the nucleic acid is two-stranded
 - the nucleic acid is single-stranded

61. Assuming Hardy-Weinberg equilibrium, the genotype frequency of heterozygotes, if the frequency of the two alleles at the gene being studied are 0.6 and 0.4, will be:
- 0.80
 - 0.64
 - 0.48
 - 0.32
62. Cholecalciferol (vitamin D), in order to become biologically active undergoes hydroxylation at two positions in the molecule. Hydroxylation at the 25th position is done in the liver whereas hydroxylation at the 1st position occurs in
- skin
 - pancreas
 - intestine
 - kidney
63. MHC-I groove can be loaded with peptides of only 8–10 amino acids because
- MHC-I groove is closed on both ends
 - fragments of only 8–10 amino acids are generated in MHC-I bearing cells
 - β_2 -microglobulin of MHC-I prevents the binding of large peptides to MHC-I
 - β polypeptides of MHC-I prevents binding of 8-10 amino acid long peptides to MHC-I
64. The possible genotypes of endosperms borne on a heterozygous (Rr) plant will be
- RRR, RRr, Rrr, rrr
 - RRr, Rrr
 - RR, Rr, rr
 - Rr
65. If *E. coli* bacteria are grown in the absence of both glucose and lactose, which of the following events will occur?
- the *lac* repressor will bind to the operator sequence
 - the CAP (catabolite gene activator protein) will activate transcription
 - RNA polymerase holoenzyme will bind to the *lac* promoter and form open complex
 - the *lac* operon will be transcriptionally active
- only P
 - only Q
 - P and R
 - Q and S
66. If the flow of energy in an arctic ecosystem goes through a simple food chain from seaweeds to fish to seals to polar bears, then which of the following is *true*?
- polar bears can provide more food for people than seals can
 - the total energy content of the seaweeds is lower than that of the seals
 - polar bear meat probably contains the highest concentrations of fat-soluble toxins
 - seals are more numerous than fish

67. The Lyon hypothesis
- is best supported by evidence from skeletal muscle cell cultures
 - explains why males are more likely to exhibit sex-linked recessive traits
 - suggests that somatic mosaics can result from heterogametes
 - postulates that the inactivation of X chromosomes occurs randomly in somatic cells during development
68. An increase in the inbreeding coefficient, F , is likely to result in
- reduced likelihood of heterozygotes being present in a population
 - higher proportion of genes that show linkage
 - higher proportion of genes with introns
 - lower level of difference between proteins in two daughter cells
69. Why do scientists think RNA, rather than DNA, may have been the original genetic material?
- most organisms on Earth use RNA as their genetic material
 - the simplest life forms, viruses, use RNA
 - RNA is more stable than DNA
 - RNA has the ability to catalyze a few simple, chemical reactions
70. A solution containing NAD^+ and NADH had an optical density in a 1 cm cuvette of 0.311 at 340 nm and 1.2 at 260 nm. Calculate the concentrations of the oxidized and reduced forms of the coenzyme in the solution. Both NAD^+ and NADH absorb at 260 nm, but only NADH absorbs at 340 nm. The extinction coefficients are given below.

	ϵ ($\text{M}^{-1} \times \text{cm}^{-1}$)	
Compound	260 nm	340 nm
NAD^+	18,000	~ 0
NADH	15,000	6220

- $[\text{NADH}] = 5 \times 10^{-5} \text{ M}$ and $[\text{NAD}^+] = 2.50 \times 10^{-5} \text{ M}$
- $[\text{NADH}] = 2.5 \times 10^{-5} \text{ M}$ and $[\text{NAD}^+] = 5 \times 10^{-5} \text{ M}$
- $[\text{NADH}] = 1 \times 10^{-5} \text{ M}$ and $[\text{NAD}^+] = 2 \times 10^{-5} \text{ M}$
- $[\text{NADH}] = 6.5 \times 10^{-5} \text{ M}$ and $[\text{NAD}^+] = 2 \times 10^{-5} \text{ M}$

PART-C

71. Which of the statements are *correct*? Spliceosomes
- are composed of RNA and protein
 - recognize RNA sequences that signal for removal of introns
 - can produce different mRNA molecules by splicing at alternate site
 - mediates splicing of group I introns
- P and Q
 - P, R and S
 - P, Q and R
 - P, Q, R and S

72. Tyrosine kinase receptors
- P. should be trimerized to be active
 - Q. play important role in activating signal transduction cascades
 - R. have phosphate-removing active sites in their cytosolic tails
 - S. can be oncogenes
- a. P and Q
 - b. Q only
 - c. P, Q and R
 - d. Q and S
73. Which of the following statements are *true* with respect to membrane fluidity of a phospholipid bilayer?
- P. increasing proportion of long chain fatty acids decreases membrane fluidity
 - Q. increase in cholesterol content increases membrane fluidity
 - R. increasing proportion of *cis* unsaturated fatty acids increases membrane fluidity
 - S. increasing proportion of *trans* unsaturated fatty acids increases membrane fluidity
- a. P and Q
 - b. P and R
 - c. R and S
 - d. Q and S
74. Which of the following are the mechanism of action of antibiotics?
- P. interfere with bacterial cell wall synthesis
 - Q. inhibit bacterial transcription of DNA
 - R. inhibit translation of bacterial mRNA
 - S. change the permeability of plasma membrane
- a. P and Q
 - b. R and S
 - c. P, Q and R
 - d. P, Q, R and S
75. In humans, the SRY gene
- P. codes testis-determining factor
 - Q. present on the Y chromosome
 - R. activates (either directly or indirectly) the SF1 gene
 - S. inhibits the WNT4 gene
- a. P and Q
 - b. P and S
 - c. P, Q and R
 - d. P, Q, R and S

76. A generalized illustration of the performance of a species in respect of an environmental condition is shown below. What does range P, Q and R most likely represent?

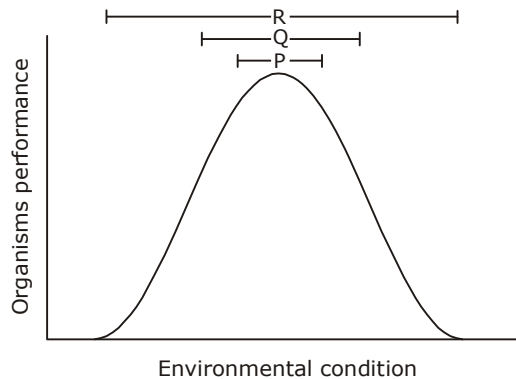

- a. P survival, Q growth, R reproduction
 b. P growth, Q survival, R reproduction
 c. P reproduction, Q survival, R growth
 d. P reproduction, Q growth, R survival
77. Which of the following statements are *true*?
- P. Evolution means descent with modification
 Q. Darwin's theory of evolution by natural selection explains evolutionary change and adaptation
 R. Darwin's theory of evolution is based on the concept of natural selection
- a. P and Q
 b. Q and R
 c. P and R
 d. P, Q and R
78. A protein that has been synthesized *not* in cytosol:
- P. Was most likely synthesized in smooth endoplasmic reticulum
 Q. Was most likely synthesized in rough endoplasmic reticulum
 R. Will leave through the *trans* side of endoplasmic reticulum
 S. Will enter into the *cis* side of Golgi
- a. P only
 b. P and R
 c. Q and S
 d. Q and R

79. What is the co-transduction frequency for the A and B genes, from the following dataset?
(Assume that there has been selection for the A⁺ form of the A gene).

<i>Genotype</i>	<i>Number</i>
A ⁺ B ⁺ C ⁺	10
A ⁺ B ⁺ C ⁻	30
A ⁺ B ⁻ C ⁺	20
A ⁺ B ⁻ C ⁻	40

- a. 0.10
b. 0.20
c. 0.30
d. 0.40
80. Consider the following
P. tyrannosaurus (dinosaur)
Q. lobe-finned fishes
R. great apes
S. eohippus (horse)
T. trilobites
- Which of the following represents the proper sequence, from the earliest in the fossil record to the latest, of the animals listed above?
- a. P, Q, T, S, R
b. Q, T, P, R, S
c. Q, T, P, S, R
d. T, Q, P, S, R
81. r-selected species
P. survivorship curve convex
Q. low fecundity
R. density fairly constant at or near carrying capacity
S. good dispersal process
T. low level of social organization
- a. Q and T
b. S and T
c. P, Q and R
d. R, S and T

82. Which of the following membranes have a proton-pumping ATPases?

BPM	Bacterial plasma membrane
CIM	Chloroplast inner membrane
TGM	Trans-Golgi membrane
LM	Lysosomal membrane
MIM	Mitochondrial inner membrane
VM	Vacuolar membrane

- a. BPM, CIM, MIM, and VM
- b. BPM, TGM, MIM, and VM
- c. CIM, LM, MIM and VM
- d. BPM, LM, MIM and VM

83. Which statement about the DnaB helicase are *true*?

- P. DnaB helicase is a ring-shaped molecule and the dsDNA goes through the hole
- Q. DnaB helicase is loaded onto the lagging strand by the clamp loader
- R. DnaB is loaded onto ssDNA at oriC by DnaC
- S. interaction between the tau subunit of the replisome and DnaB causes the helicase to go slower
- T. DnaB moves in 5' to 3' direction

- a. P and R
- b. R and T
- c. Q and R
- d. S and T

84. Which of the following statements are *correct*?

- P. Tundra biome is a polar desert, with very low temperature and low precipitation
- Q. Deserts are found at latitudinal positions between 15° to 35° North and South of the equator
- R. Savanna is grassland with *scattered* individual trees
- S. Temperate grasslands are characterized as having grasses as the dominant vegetation
- T. Chaparral biome is characterized by mild, rainy winters and long, hot, dry summers

- a. P, Q and R
- b. Q, S and T
- c. Q, R, S and T
- d. P, Q, R, S and T

85. Identify the *correct* statement regarding gastrulation
- P. formation of archenteron surrounded by the endoderm
 - Q. little growth so that overall size of the embryo does not increase significantly
 - R. greater activity of the nucleus and the formation of new proteins
 - S. complex but orderly and irreversible morphogenetic movements
- a. P, Q
 - b. S
 - c. Q, R
 - d. P, Q, R, S
86. Phytohormone ethylene
- P. induces the formation of adventitious root
 - Q. stimulates leaf and fruit abscission
 - R. binds with membrane bound receptors
 - S. action depends on inactivation of DELLA proteins
- a. P and Q
 - b. Q and S
 - c. P, Q and R
 - d. P, Q, R and S
87. Which of the following statements about plant are *correct*?
- P. hexose monophosphate shunt can accomplish the oxidation of glucose in the stroma of mitochondria
 - Q. ATP is produced in the reaction step of TCA cycle catalyzed by succinyl CoA synthetase
 - R. in addition to cytochrome *c* oxidase, an alternative oxidase enzyme resistant to cyanide reduces oxygen molecule in the electron transport system
 - S. in glyoxylate cycle acetyl-CoA reacts with citrate to form alpha-ketoglutarate
- a. P, R
 - b. P, Q
 - c. Q, R
 - d. Q, S
88. One of the classical examples of evolution occurs on the Galápagos Islands with Darwin's finches. All the organisms living on these islands are descendants of species that have emigrated there, primarily from South America. In studying the finch populations, researchers have identified fourteen species, none of which are found on the mainland. The initial colonizing population of finches most likely exhibited which of the following?
- a. hybridization with bird species already existing on the islands
 - b. high rates of interbreeding with mainland populations
 - c. increased rates of mutation to fill habitats
 - d. a smaller gene pool than that of the mainland populations

89. Myoglobin shows a hyperbolic response, while hemoglobin shows a sigmoidal response for oxygen binding. Which of the following statements are *true* with respect to this observation?
- P. hemoglobin binds 2, 3-BPG while myoglobin does not
 - Q. hemoglobin exists in two different conformational states while myoglobin does not
 - R. hemoglobin is a tetramer while myoglobin is a monomer
 - S. hemoglobin is present in RBCs while myoglobin is present in the muscle
- a. R and S
 - b. S and P
 - c. P and Q
 - d. Q and R
90. Plasmid A and plasmid B were digested with *Bam*HI and analyzed by agarose gel electrophoresis. If plasmid A gave two fragments and plasmid B gave three fragments, then which of the following inferences are *correct*?
- P. plasmid A has three sites and is circular
 - Q. plasmid B has three sites and is circular
 - R. plasmid A has two sites and is linear
 - S. plasmid B has two sites and is linear
- a. P and Q
 - b. Q and R
 - c. P and S
 - d. Q and S
91. Okazaki fragments are formed during DNA synthesis, because
- P. DNA synthesis extends from 5' to 3' direction
 - Q. Their synthesis are opposite to the direction of replication fork
 - R. DNA ahead of replication fork is positively supercoiled
 - S. DNA synthesis is semi-conservative
- a. Q and R
 - b. P and Q
 - c. R and S
 - d. S and P
92. A certain purified DNA sample was cut with two restriction endonucleases E1 and E2. The following results were obtained from agarose gel electrophoresis
- Sample cut with E1 alone: two bands of size 35 kb and 15 kb
 - Sample cut with E2 alone: two bands of size 40 kb and 10 kb
 - Sample cut simultaneously with E1 and E2: three bands of size 35 kb, 10 kb and 5 kb
- From these data it can be inferred that the DNA has
- a. two sites for E1 and one site for E2
 - b. one site for E1 and two sites for E2
 - c. one site each for E1 and E2
 - d. three sites for E1 and one site for E2

93. In column I are given equations and in column II what the equations represent. Column I and II are incorrectly matched.

Column I

P. $\frac{dN_1}{dt} = r_1 N_1 \left(\frac{K_1 - N_1}{K_1} \right)$

Q. $\frac{dN_1}{dt} = r_1 N_1$

R. $\frac{dN_1}{dt} = r_1 N_1 \left(\frac{K_1 - N_1 - \alpha N_2}{K_1} \right)$

S. $\frac{dN_1}{dt} = N_1 b_1 - d_1 N_1 N_2$

Column II

1. population growth of species 1 in the presence of competing species 2
2. logistic population growth of species 1
3. population growth of prey species 1 in the presence of predator species 2
4. exponential population growth of species 1.

The *correct* match in sequence of the four equations from column I is

- a. 2, 4, 1 and 3
 - b. 4, 2, 1 and 3
 - c. 2, 4, 3 and 1
 - d. 4, 2, 3 and 1
94. When numbers of organisms and amounts of living material in successively higher trophic levels are compared, the values usually take the form of a pyramid, with the largest numbers and greatest biomass in the producer trophic level. However, in some marine ecosystems, the consumer trophic levels contain significantly greater amounts of living material than does the primary-producer trophic level. The best explanation for this is which of the following?
- a. the main primary producers in marine ecosystems are microscopic algae with extremely high rates of population turnover
 - b. most consumers in marine ecosystems are filter feeders that must maintain large basket like structures for extracting food from the water
 - c. the increased availability of solar radiation in marine ecosystems means that fewer primary producers are required to support marine food chains
 - d. marine zooplankton often produce large extensions of their bodies in order to increase buoyancy
95. In *Drosophila*
- P. sex is determined by the ratio of X chromosomes to sets of autosomes
 - Q. the Y chromosome does not play a role in sex determination
 - R. there are no sex hormones, so each cell makes a sex determination decision
 - S. Sxl gene is activated in females and is repressed in males
- a. P and Q
 - b. P and S
 - c. P, Q and R
 - d. P, Q, R and S

96. Which arrangement correctly identifies the type of blood that the four chambers of the heart collect and pump?

	<i>right atrium</i>	<i>right ventricle</i>	<i>left atrium</i>	<i>left ventricle</i>
a.	oxygenated	deoxygenated	oxygenated	deoxygenated
b.	deoxygenated	oxygenated	deoxygenated	oxygenated
c.	deoxygenated	deoxygenated	oxygenated	oxygenated
d.	oxygenated	oxygenated	deoxygenated	deoxygenated

97. Match the terms in group I with terms in group II

Group I

P. RNase-P

Q. Leucine zipper

R. RNA pol-I

S. Attenuation

Group II

1. *lac* operon

2. rRNA gene transcription

3. tRNA gene transcription

4. Transcription factors

5. Ribozymes

6. *trp* operon

7. mRNA splicing

a. P-7, Q-5, R-3, S-1

b. P-4, Q-5, R-2, S-1

c. P-5, Q-4, R-2, S-6

d. P-4, Q-5, R-3, S-6

98. Fibroblasts Endothelium

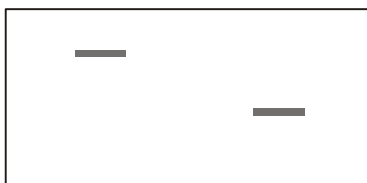

Two tissue cultures are established, one with human fibroblasts and one with human endothelial cells. After the cells have grown to confluence, mRNA is isolated from each culture and analyzed on a Northern blot with a ³²P-probe complementary to the coding strand of Gene X. The results are shown above. Which of the following represents the best conclusion from these data?

a. allelic exclusion in the Gene X locus of endothelium but not in fibroblasts

b. gene X contains different restriction endonuclease sites in the fibroblasts and endothelium

c. gene X is on a different chromosome in the endothelium and the fibroblasts

d. there is alternative splicing of the hnRNA in endothelium and fibroblasts

99. Directional selection
- P. occurs due to the change in the environment in particular direction
 - Q. favours the phenotype which is non-average or extreme
 - R. eliminate normal or average individuals
 - S. keeps a population genetically constant
 - T. introduce homozygosity in the population
- a. P, R and S
 - b. P, Q and R
 - c. Q, S and T
 - d. P, S and T
100. Ethylene
- P. amino acid lysine is the precursor of ethylene
 - Q. amino oxyacetic acid and cobalt ion block the biosynthetic pathway of ethylene
 - R. stimulates leaf and fruit abscission
 - S. binds with membrane bound receptors
 - T. Trans-cyclooctene acts as inhibitor of ethylene action because they block ethylene binding to its receptor
- a. R, S and T
 - b. P, Q, R and T
 - c. P, Q, R and S
 - d. Q, R, S and T
101. X-chromosome inactivation is
- P. yielding a completely inactive X-chromosome
 - Q. yielding a mostly inactive X-chromosome
 - R. controlled via two special non-coding RNAs
 - S. controlled via two special proteins
- a. P only
 - b. R only
 - c. Q and R
 - d. P, R and S
102. Which of the following statements are *incorrect* on ecological point of view?
- P. primary succession involving xerosere is initiated in a wet habitat
 - Q. halones commonly found in electronic equipment are one of the active force destroying the protective ozone layer in the stratosphere
 - R. sympatric speciation occurs when the new species evolves in geographic isolation from the parent species
 - S. α -diversity is the diversity of species within a habitat or community
- a. P, Q
 - b. P, R
 - c. Q, R
 - d. Q, S

103. In some sheep, the presence of horns is produced by an autosomal allele that is dominant in males and recessive in females. A horned female is crossed with a hornless male. One of the females of F_1 is crossed with a hornless male. What proportion of the male and female progeny from this cross will have horns? What is type of inheritance?
- 1/2 male progeny will be horned; maternal inheritance
 - 1/2 male progeny will be horned; maternal effect
 - 1/2 male will be horned; sex-linked
 - 1/2 male will be horned; sex-influenced
104. Which among following statement is *incorrect*?
- linking number of discontinuous 2100 bp circular plasmid is 200
 - linking number is sum of twist and writhe
 - twist and writhe always need to be integer
- only P
 - only R
 - P and R
 - only Q
105. Sexual reproduction in plants
- involve gametes formation and fertilization
 - occurs through formation of sexual spores
 - occurs through formation of meiospores
 - produce genetically identical offspring
- P and Q
 - Q, R and S
 - P, Q and R
 - P, Q and S
106. Compared to cones, rods can detect light at lower intensities because
- rods are larger than cones
 - rods can increase their sensitivity to lights more quickly than cones
 - rods have larger receptive fields than cone
 - rods are more concentrated than cones in forea
- P, Q and R
 - P and R
 - Q and S
 - P, Q, R and S

107. Considering complement fixation in human, what is *correct*?
- P. C5 convertase is formed from C5a and C5b
 - Q. C5 convertase is formed from C3b and C3 convertase
 - R. C3a and C3b are formed by C5 convertase
 - S. the membrane attack complex consist of C5b, C6, C7, C8 and C9
- a. P and R
 - b. Q and S
 - c. Q, R and S
 - d. R and S
108. Which of the following is *not* associated with germination of seed?
- P. increase in water content
 - Q. resumption of metabolism
 - R. intake of oxygen
 - S. intake of carbon dioxide
- a. P and Q
 - b. only S
 - c. P and S
 - d. R and S
109. A diploid somatic cell from a rat has a total of 42 chromosomes ($2n=42$)
- P. rat has 21 different chromosomes
 - Q. rat has 42 DNA molecules in the nucleus during G1
 - R. rat has 21 bivalents in metaphase I of meiosis
 - S. rat has 42 DNA molecules in metaphase II of meiosis
- a. P and Q
 - b. Q and S
 - c. P, Q and R
 - d. P, Q, R and S
110. Which of the following statement is *true*?
- P. abscisic acid induces formation of winter buds by suppressing growth
 - Q. auxin is produced primarily in the apical meristems of plants
 - R. in angiosperm reproduction, only a single pollen is involved in fertilization process
 - S. cytokinins in combination with auxins stimulates cell division in plants and determines course of differentiation
- a. P, Q and R
 - b. P, Q and S
 - c. Q and S
 - d. Q, R and S

111. Thin layer chromatography is widely used technique for separation of small solutes of different polarity. In one experiment you used silicic acid support over metal film to separate lipids constituent of erythrocyte cell membrane (figure shown). What does point corresponds to if solvent used was chloroforms, methanol and water mixture.

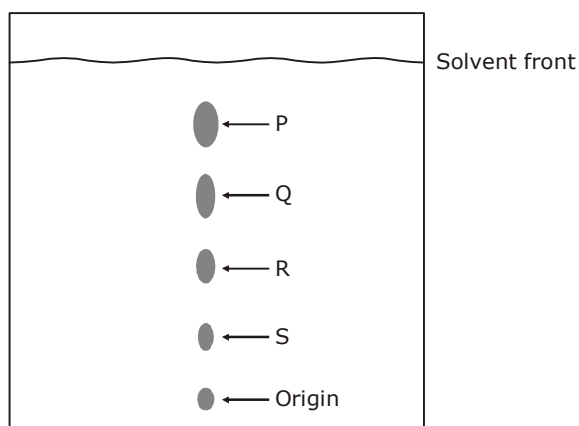

- a. P-cholesterol, Q-phosphotidyl ethanolamine, R-phosphotidylcholine, S-phosphotridyl serine
 b. P-phosphotidyl ethanolamine, Q-phosphotidylcholine, R-phosphotridyl serine, S-cholesterol
 c. P-phosphotridyl serine, Q-phosphotidylcholine, R-phosphotidyl ethanolamine, S-cholesterol
 d. P-cholesterol, Q-phosphotidyl ethanolamine, R-phosphotridyl serine, S-phosphotidylcholine
112. In terms of the cell cycle, cancer cells differ from normal cells in which of the following ways?
- P. cancer cells pass through the phases of the cell cycle in sequences different from that of normal cells
 Q. cancer cells do not stop dividing when they come in contact with other cells as normal cells do
 R. cancer cells are able to divide an indefinite number of times, while normal cells divide a limited number of times
 S. cancer cells are more sensitive to changes in external factors than are normal cells, and alter their division rates accordingly
- a. P and R only
 b. Q and R only
 c. Q and S only
 d. P, Q, and S only
113. In an experiment, honey bees is first exposed to its predator kept in box of blue colour and then kept in cage for different interval of time; $t = 1$ day and $t = 5$ day. During subsequent exposure of honey bees it was found that it choosed the blue background to enter $2/3$ times in total of 99 such attempts, when exposed after $t = 5$ days however it choosed the blue background 40 times when same number of attempts were made after $t = 1$ day. What can be concluded from experiments.
- P. honey failed to associate background colour and predator presence in box
 Q. memory to relate colour background with predator lasts only for 1 day in honey bees
 R. honey bees have ability to relate colour background with predator's presence for upto and above 5 days
- a. only P
 b. only Q
 c. only R
 d. P and Q

114. An experiment was conducted in *E. coli* to map the following genes (pro, his, bio, met, phe and trp) on a circular map using 3 different Hfr strains.

Strain 1 Order of transfer (early to late):	trp	met	his	pro
Strain 2 Order of transfer (early to late):	his	met	trp	bio
Strain 3 Order of transfer (early to late):	pro	phe	bio	trp

Based on the results what is the most likely map?

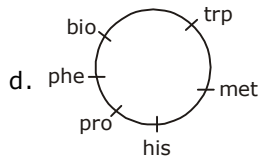
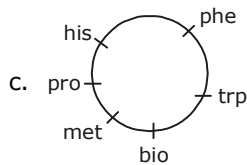
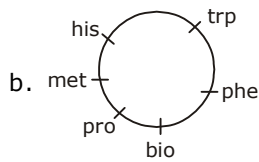
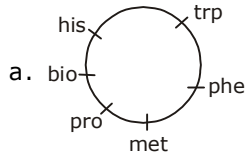

115. Which of the following is/are *correct* about phytoextraction?

- P. process used by the plants to accumulate contaminants into the roots and aboveground shoots
 - Q. uptake of organic contaminants from soil or water and, subsequently, their transformation to more stable, less toxic form.
 - R. process in which plants reduce the mobility and migration of contaminants and contaminated soil
 - S. process of the breakdown of contaminants due to the presence of proteins and enzymes produced by the plants
- a. only P
 - b. only Q
 - c. P and R
 - d. R and S

116. I

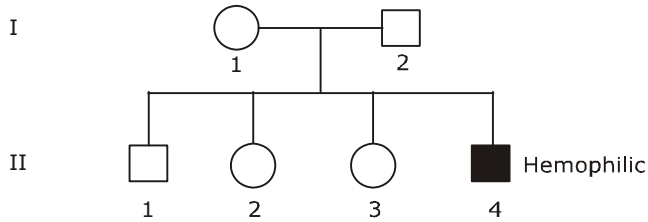

Hemophilia is a recessive sex-linked disease. From the information in the pedigree

P. I1 must be a carrier

Q. II3 has a 50% chance of being a carrier of hemophilia (Hh)

R. If II3 marries a hemophilic man, 50% of their child are expected to be hemophilic

S. If II3 marries a hemophilic man, the probability that her first child will be normal is 75%

a. P and Q

b. P, Q and R

c. R and S

d. P, Q, R and S

117. A piece of prospective belly epidermis of a newt neurula-stage embryo is grafted to the prospective mouth region of a frog neurula, replacing the frog epidermal tissue at that spot. The grafted embryo continues to develop and forms a newt mouth and teeth at the position of the graft. This result is consistent with which of the following?

a. newt tissue develops autonomously according to its original fate, despite its new location in the frog embryo

b. newt tissue dedifferentiates whenever it is grafted

c. tissues of the frog neurula induce the newt tissue to express frog-specific genes that it would not normally express

d. the frog tissues of the neurula induce the newt tissue to form mouthparts

118. Potential advantages of adenovirus based vector for gene delivery in human

P. integrates into host cell genome providing stable gene expression

Q. can contain >30 kb of nonviral DNA

R. infects both non-dividing and dividing cells

S. does not provide long-term gene expression due to lack of integration

a. P and Q

b. Q and S

c. Q and R

d. P, R and S

119. Which of the following are the properties of transformed cells
- P. anchorage independent
 - Q. contact inhibition; monolayer culture
 - R. dependent on external growth factor
 - S. immortal or continuous cell lines
- a. P and Q
 - b. Q and R
 - c. P and S
 - d. P, R and S
120. Which of the following are the characteristics of type II restriction endonucleases?
- P. Nature of enzyme : Bifunctional enzyme with both endonuclease and methylase activity
 - Q. Protein structure : Two identical subunits
 - R. Restriction requirement : ATP, Mg²⁺
 - S. Cleavage sites : At or near restriction site
- a. P and Q
 - b. Q and S
 - c. P and S
 - d. R and S
121. MicroRNAs (miRNAs)
- P. are synthesized as long *pri-miRNAs* (up to 1000 nt)
 - Q. are transcribed by RNA polymerase II
 - R. are synthesized from *pre-miRNAs* by an RNase III enzyme drosha in the cytoplasm
 - S. are synthesized from *pri-miRNAs* by an enzyme dicer in the nucleus
- a. P and Q
 - b. Q and S
 - c. P and S
 - d. R and S
122. A student inspired by Meselson and Stahl experiment want to know what happens to histones during eukaryotic DNA replication. He designed protocol whose steps are below:
- Step 1 : grow cells for several generations in medium that contains amino acids labeled with a heavy isotope
- Step 2 : transfer the cells to a medium that contains amino acids with light isotope
- Step 3 : isolate histone octamers before and after replication and subject them to density gradient centrifugation
- Observation : octamer prior to replication shown single band lower in test tube while after replication octamer shown broad band but upper in position in comparison to earlier band.
- The correct conclusion will be
- a. histone followed semi-conservative model of replication like DNA
 - b. after DNA replication, the new octamers are a random mixture of old and new histone
 - c. new octamer and old octamer are in 1 : 1 after DNA replication
 - d. nothing happened to old histones, they remained intact

123. Green Fluorescent Protein (GFP)
- P. encoded by gene of bioluminescent jellyfish *Aequorea victoria*
 - Q. discovered by Shimomura
 - R. amino acid residues 65-67 (Ser-Tyr-Gly) form the fluorescent chromophore
 - S. it fluoresces with a peak wavelength of 508 nm (green light) when irradiated by UV or blue light (optimally 400 nm).
- a. P and Q
 - b. Q and R
 - c. P and S
 - d. P, Q, R and S

124. From data given below. What can be concluded *correct*?

	Substrate	K_{cat} (S^{-1})	K_M
Catalase	H_2O_2	4×10^7	1.1
Crotonase	Crotonyl-CoA	5.7×10^3	2×10^{-5}
Fumarase	Fumarate	8×10^2	5×10^{-6}

- P. number of molecules of substrates converted to product per second on a single enzyme is highest for catalase
 - Q. the highest affinity for substrate is by catalase
 - R. crotonase has highest catalytic efficiency
- a. P and R
 - b. Q and R
 - c. P and Q
 - d. only P

125. Which of the following statements are *correct*?

- P. organisms produce many more offspring than can survive, which results in a struggle for existence
 - Q. natural selection will operate among any entities that reproduce, show inheritance of their characteristics from one generation to the next
 - R. selection may be directional, stabilizing, or disruptive
 - S. in the absence of natural selection, and with random mating in a large population in which inheritance is Mendelian, the genotype frequencies at a locus move in one generation to the Hardy-Weinberg ratio; the genotype frequencies are then stable
- a. P and Q
 - b. P, Q and R
 - c. Q and S
 - d. P, Q, R and S

126. A mutant of *E.coli* was found which did not synthesize β -galactosidase in the presence as well as in the absence of the inducer, IPTG. The investigation revealed that the structural genes of the *lac* operon were unaltered in the mutant, but one of the controlling genes (I or O) was mutated. The different allelic forms of the regulator gene and the operator gene are as follows

I⁺-wild type regulator gene

I^c-Constitutive regulator

I^s-Repressor form which is insensitive to inducer













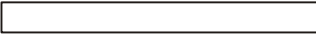

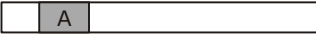

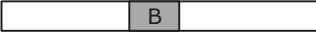
O⁺-Wild type operator gene

O^c-Constitutive operator

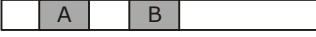
Which of the following mutation in the controlling genes was responsible for the above mentioned behaviour of the *E.coli* mutant?

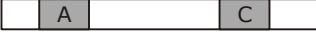
- a. I⁺O⁺
- b. I^c O⁺
- c. I^s O⁺
- d. I⁺ O^c

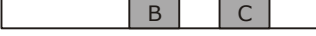
127. Lkp1, is a protein produced in liver and kidney cells. The *LKP1* gene is not expressed in heart cells. When DNA upstream of *LKP1* is placed upstream of the gene for green fluorescent protein, GFP is expressed in liver and kidney cells but not in heart cells—the normal expression of LKP1. Three regulatory regions, A, B, and C, control this expression pattern. A unique transcription factor binds each site such that site A is bound by protein X, site B by protein Y, and site C by protein Z. Mutations were made in each of these regulatory segments. If the site is missing below, it is mutated such that it cannot bind its corresponding transcription factor. Which protein act as repressors?

Experiment	Promoter region for LKP1	GFP	Expression in		
			Liver?	Kidney?	Heart?
1			Yes	Yes	No
2			No	No	Yes
3			No	Yes	Yes
4			Yes	No	Yes
5			No	No	No
6			Yes	Yes	Yes
7			No	Yes	No
8			Yes	No	No

- a. factor X
- b. factor Y
- c. factor Z
- d. none of the above

128. *E. coli* has a circular DNA consisting of 4.3×10^6 bp. There are 10 bp of DNA for each complete 360° turn of the double helix. Replication starts at one location in the genome and proceeds in both directions; that is, there are two replication forks that move away from the origin of replication in opposite directions meeting when each has moved half way around the genome. Under one particular set of growth conditions, 800 bp of DNA are formed per second at each replication fork. At how many revolutions per minute (rpm) is each replication fork rotating during replication?
- 4800 rpm
 - 800 rpm
 - 9600 rpm
 - 8 rpm

129. Human blood types are genetically determined. The table below shows the symbols used to represent two of the alleles for blood types and gives a description of each allele.

Two alleles controlling human blood type

<i>Symbol</i>	<i>Allele description</i>
I^A	produces antigen A on red blood cells
I^B	produces antigen B on red blood cells

In homozygous individuals, two I^A alleles result in blood type A and two I^B alleles result in blood type B. The I^A and I^B alleles are codominant, resulting in blood type AB in individuals heterozygous for the two alleles. A male and a female both have blood type AB. If they have a child, what is the probability that the child will also have blood type AB?

- 1/4
 - 1/2
 - 3/4
 - 1
130. What can be concluded from following table?

Site	Productivity per unit weight (g/leaf biomass year ⁻¹)	Productivity per unit area (g/ biomass m ⁻² year ⁻¹)
Deserts	2.33	90
Deciduous forest	2.22	1200
Coniferous forest	1.64	1300
Grassland	1.21	600

- P. deserts are less dense vegetation as compared to deciduous forest
 Q. deciduous plants are less productive than deserts on a weight-for-weight basis
- only P
 - only Q
 - neither P nor Q
 - both P and Q

131. A retrotransposon would be best described as
- P. a mobile DNA element that can also reproduce as a virus
 - Q. a transposable element that passes through an RNA intermediate
 - R. a transposable element that cuts and moves the DNA from one site to another
 - S. transposable element that show homing
- a. only P
 - b. only Q
 - c. P and Q
 - d. R and S
132. In one study on development in sea urchin eggs scientists exposed newly fertilized eggs either to cycloheximide or actinomycin D immediately, following fertilization. In presence of cycloheximide, the fertilized egg failed to divide while in presence of actinomycin D the egg divided several times to reach an early embryonic stage blastula. Data is also obtained on effect of differential treatment on protein synthesis (figure).

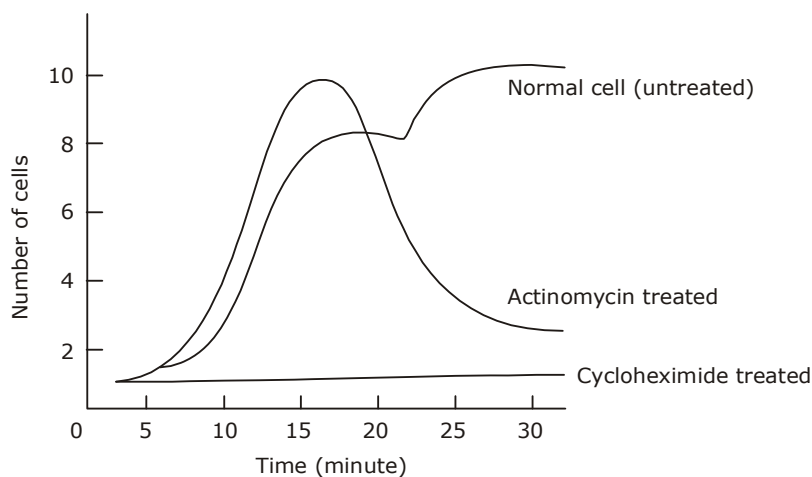

It can be concluded.

- P. mRNA needed for earliest stages in sea urchin development must be present already
 - Q. gene expression is not necessary for earliest of sea urchin development
 - R. gene expression is necessary for further progression of cells beyond early stage
 - S. from experiment it can be concluded that actinomycin D prevented cell cycle protein expression
- a. P and Q
 - b. P and R
 - c. P, Q and R
 - d. P, Q, R and S

133. The pedigree below shows an autosomal dominant disease in a family. All affected individuals are shown. Below the pedigree are Southern blot results for a closely linked polymorphic Short Tandem Repeat (STR) with four alleles (W through Z). Each blot result is directly below the tested individual. What is the predicted status of the unborn child II-3? Assume no recombination has taken place.

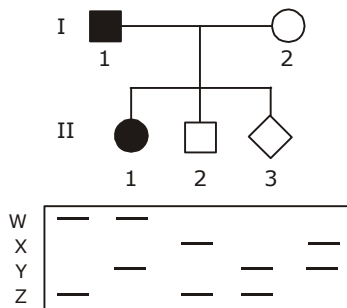

- a. almost certainly affected, and heterozygous for the disease gene
 b. almost certainly affected, and homozygous for the disease gene
 c. almost certainly unaffected
 d. the marker is uninformative for predicting the status of II-3
134. A species of plant is discovered in which individual plants produce either white or purple flowers. True breeding plants that have short stems with white flowers are crossed with true breeding plants that have tall stems and purple flowers. The resulting offspring all have tall with purple flowers. When one of these tall, purple-flowered offspring is crossed with a short, white-flowered plant, plants with the following characteristics were obtained in equal proportions. White flowers on tall stems, Purple flowers on tall stems, White flowers on short stems, Purple flowers on short stems. Given the information above, which of the following is most likely true?
- a. the white-flower allele and the tall-stem allele occur at the same locus
 b. the genes for flower color and stem length are closely linked
 c. extensive crossing-over between the purple-flower allele and the white-flower allele has occurred
 d. the genes for flower color and stem length are not linked
135. According to ABC model, three classes of genes control floral organ identity in *Arabidopsis thaliana*. Model postulates class A genes specify sepal identity in whorl 1 (outer one) and do not require class B or C genes to do so. Similarly, class C genes specify carpel identity in whorl 4 and again do so independently of class A or B genes. In contrast petals in whorl 2 are specified by class A and B genes and stamens in whorl 3 are specified by class B and C genes. Also, A gene repress C genes in whorls 1, 2 and conversely C genes repress A genes in whorls 3 and 4. Using this model match the following.
- | | |
|---------------------------------|--|
| <i>Loss of function mutants</i> | <i>Phenotype (in order whorl 1 to 4)</i> |
| P. A | α. sepal-petal-petal-sepal |
| Q. B | β. sepal-sepal-carpel-carpel |
| R. C | γ. carpel-stamen-stamen-carpel |
- a. P-γ, Q-β, R-α
 b. P-α, Q-β, R-γ
 c. P-α, Q-γ, R-β
 d. P-γ, Q-α, R-β

136. Impulse transmission across a synapse

1. Neurotransmitters attach to receptor molecules on the postsynaptic neuron
2. Neurotransmitters are destroyed by an enzyme.
3. Neurotransmitters diffuse across the synapse
4. An impulse travels along the axon of the presynaptic neuron
5. Neurotransmitters are released from the presynaptic neuron

The correct sequence of events that would occur when a nerve impulse crosses a synapse is

- a. 5, 1, 4, 3, 2
- b. 4, 5, 3, 1, 2
- c. 3, 1, 5, 4, 2
- d. 3, 1, 4, 2, 5

137. What can be concluded from following data

Number of individuals			
	Sample 1	Sample 2	Sample 3
Flower species	335	20	400
Daisy	365	49	600
Buttercup	300	931	Extinct

Diversity

P. in case of sample 2 is more as compared to sample 3

Q. is same in sample 1 and sample 2

R. is maximum in sample 1

S. is maximum in sample 2

- a. P and Q
- b. only S
- c. P and R
- d. only Q

138. Which combination of the following statements with regard to gene expression is *true*?

P. Heteronuclear RNA represents contiguous segment of genomic DNA

Q. UTRs are part of heteronuclear RNA but not of mRNA

R. UTRs are part of exons

S. Translation start codon *must* be in the first exon

- a. P - true, Q - false, R - false, S - false
- b. P - true, Q - false, R - true, S - false
- c. P - true, Q - true, R - false, S - true
- d. P - false, Q - true, R - true, S - true

142. Aneuploidy arises as a random error during the production of gametes. Aneuploidy arises if, during one of the divisions of meiosis, one of the homologous chromosomes in meiosis I (or chromatids in meiosis II) does not migrate to the opposite pole. This results in an uneven distribution of that particular chromosome. Depending upon where in meiosis this nondisjunction occurs, some gametes will end up with one or more extra chromosomes and others will end up with fewer chromosomes than a complete set. Which of the following genetic events can produce an XYY man?
- non-disjunction in first meiotic division
 - non-disjunction in the second meiotic division in the cell with two Y chromatids
 - non-disjunction in the first meiotic division in the cell with two Y chromatids
 - non-disjunction in the second meiotic division in the cell with two X chromatids
143. A disease free tomato plant was planted in soil contaminated with *Agrobacterium tumefaciens* harboring Ti plasmid that lacks VirA gene. Provided all other conditions are optimum for the bacterial infection, identify the appropriate consequence
- octopine synthesis by the bacterium will enhance
 - acetylsyringone receptor will not be synthesized
 - the bacteria will fail to transfer the T-DNA to the plant
 - a fragmented T-DNA will be transferred to the tomato plant
- P, S
 - Q, S
 - P, R
 - Q, R
144. Which of the following statement(s) about retroviruses and/or retrotransposons is/are *false*?
- they both use the enzyme reverse transcriptase to copy their RNA genomes into double stranded DNA
 - the reverse transcriptase of retroviruses and retrotransposons is structurally related to the transposase of DNA transposons
 - retroviruses are infectious while retrotransposons are endogenous mobile elements
 - short target site duplications are characteristic of both types of elements, as well as DNA transposons, when they insert into chromosomal DNA
 - retroviruses and many retrotransposons have long terminal repeats (LTRs) flanking their coding regions
- only Q
 - only T
 - R and S
 - P, Q and S

145. A major group of G protein-linked receptors contain seven transmembrane alpha helices. The amino end of the protein lies at the exterior of the plasma membrane. Loops of amino acids connect the helices either at the exterior face or on the cytosol face of the membrane. The loop on the cytosol side between helices 5 and 6 is usually substantially longer than the others.

P. the carboxyl end located at the cytosolic side which interact with G protein

Q. the carboxyl end located at the non-cytosolic side which interact with signal molecule

R. the amino end located at the cytosolic side which interact with G protein

S. the amino end located at the non-cytosolic side which interact with signal molecule

a. P and Q

b. Q and R

c. P and S

d. P, Q and R

ANSWER SHEET

CSIR-JRF-NET : MOCK TEST

PART-A

01. a	02. c	03. d	04. d	05. c	06. b	07. b	08. c
09. b	10. d	11. c	12. d	13. b	14. c	15. a	16. c
17. d	18. b	19. b	20. d				

PART-B

21. c	22. c	23. a	24. b	25. d	26. b	27. a	28. c
29. d	30. b	31. a	32. d	33. a	34. b	35. d	36. a
37. c	38. c	39. b	40. b	41. a	42. c	43. c	44. d
45. d	46. a	47. b	48. c	49. b	50. c	51. b	52. b
53. a	54. b	55. b	56. b	57. c	58. c	59. c	60. d
61. c	62. d	63. a	64. a	65. c	66. c	67. d	68. a
69. d	70. a						

PART-C

71. c	72. d	73. b	74. d	75. d	76. d	77. d	78. c
79. d	80. d	81. b	82. d	83. b	84. d	85. d	86. c
87. c	88. d	89. d	90. d	91. b	92. c	93. a	94. a
95. d	96. c	97. c	98. d	99. b	100. d	101. c	102. b
103. d	104. c	105. c	106. b	107. b	108. b	109. d	110. b
111. a	112. b	113. b	114. d	115. a	116. d	117. d	118. c
119. c	120. b	121. a	122. b	123. d	124. a	125. d	126. c
127. c	128. a	129. b	130. d	131. b	132. c	133. c	134. d
135. a	136. b	137. c	138. b	139. a	140. a	141. a	142. b
143. d	144. a	145. c					